

Experimental protocol for validation of Computational Fluid Dynamics palaeoecological simulations

Harriet B. Drage¹, Stephen Pates² and Nicholas J. Minter³

¹Institute of Earth Sciences, University of Lausanne, Switzerland; harriet.drage@unil.ch

²Department of Zoology, University of Cambridge, UK; sp587@cam.ac.uk

³School of the Environment, Geography, and Geosciences, University of Portsmouth, UK; nic.minter@port.ac.uk

Abstract

Computational Fluid Dynamics (CFD) simulations are increasingly used to test palaeoecological hypotheses. These analyses output simulated velocity and pressure flow profiles, and drag and lift force values acting on a model. These outputs are presumed to be internally consistent, assuming consistently applied parameters, but it is unclear whether these reflect real-world force measurements. Without having certainty in the simulated force outputs, we risk the resulting palaeoecological hypotheses lacking robustness. To test the difference between simulated and real-world force values, Experimental Fluid Dynamics (EFD) analyses using flume tanks can be performed, though these have rarely been done for palaeobiological research. We present ongoing, preliminary work to produce a broadly applicable protocol for performing EFD analyses to validate CFD results. We discuss digital model production and the considerations involved in 3D printing models to use in EFD, present the low-cost, open-source circuitry equipment used to measure forces, and display the jig built to support the circuitry above the flume tank during experiments. This protocol is undergoing refinement prior to data collection, including the method to attach the load cells to the jig and the material used for the beam connecting the model to the jig. Following refinement, this protocol will be consequently updated, and a series of validation values will be produced for major early Palaeozoic arthropod body plans under different flow regimes in varied water column positions. These values can be used to validate CFD results of varied future studies, and the protocol replicated to support others in performing EFD validation of palaeoecological hypothesis-testing experiments.

Key words: Arthropoda, drag force, lift force, Trilobita, experimental validation, flume tank

Introduction

Computational Fluid Dynamics (CFD) methods are becoming more frequently employed to quantitatively test palaeoecological hypotheses for extinct animals, including how they moved, how they fed, and where they lived in the water column. Amongst others, CFD analyses on invertebrates have been used to test assumptions about feeding behaviours (e.g., in arthropods, Bicknell et al., 2023; in echinoderms, Rahman et

al., 2015, 2020), locomotory hypotheses (e.g., in trilobites, Esteve et al., 2021; Song et al. 2021; Esteve & López-Pachón, 2023; *Isoxys* arthropods, Pates et al., 2021), gill function (Hou et al., 2023), the life orientations of sessile organisms (e.g., Liu et al., 2022), and general shape hydrodynamic adaptations (e.g., Hebdon et al., 2020; Pates & Drage 2024). CFD experiments produce simulations of the fluid flow around an object, such as a 2D or 3D animal model, including visual representations of velocity and pressure profiles, as well as estimated values of the drag and lift forces exerted on the object by the fluid (Rahman, 2017) (Fig. 1). These simulated results are then used to determine whether the hypothetical ecological modes are feasible, given a particular fluid flow, or how different morphological features would perform hydrodynamically in different fluid contexts (Rahman, 2017). The methods and application of CFD to palaeobiological research have been usefully reviewed by Rahman (2017), Gibson et al. (2020), and Gutarra & Rahman (2022).

Robust assessment of palaeoecological hypotheses therefore rests upon the validity of these simulated forces. However, while these are presumed to be internally consistent (assuming consistently applied protocol during analysis), the absolute values, and even magnitudes, of these forces often lack validation to ensure their accuracy. This is further complicated by the frequent extremely low values of these forces, due to the slow fluid flow regimes presumed for Earth's past (and present) water bodies and the small sizes of many animals, which means that validation experiments for more traditional engineering applications for CFD around larger objects and faster flow speeds cannot be used. The resulting Reynolds numbers (a measure predicting fluid flow patterns) are therefore very low, which can complicate flow simulations (e.g., Rauen et al. 2008; Li & Nielsen 2011).

To date, very few studies have attempted experimental validation of their CFD analyses. Several historical studies, prior to the first application of CFD in palaeobiology, investigated hydrodynamic (or aerodynamic) impact on fossil preservation, though these are not usually directly comparable to present-day CFD simulations. For example, Lask (1993) analysed the settling of trilobite sclerites in water to investigate the preservation of fossil sclerite orientations. Fortey (1985) analysed the streamlining of putative pelagic trilobite forms and terrace ridges. Plotnick & Baumiller (1988) tested a potential hydrodynamic function (as a steering rudder) for the telson of pterygotid eurypterids. Jacobs et al. (1994) recorded forces acting on ammonoid models in flume tank experiments, and Miller (1972) and Pearson (2017) explored water filtering through trinucleimorph trilobite fringe pits, both of which are potentially comparable to future CFD outputs. Palmer (2011) constructed model pterosaur wings, testing the aerodynamism in wind tunnel experiments, and comparing them to aerofoils; the results may also be comparable to future CFD simulations. Other experimental studies analysed flow around echinoderm models to test a variety of functional morphological hypotheses (see summary in Rahman 2020). Several recent studies carried out experiments that provide limited comparison to CFD simulations. Li et al. (2022) tested the drag forces acting on a model of the Cambrian arthropod *Ercaicunia multinodosa* placed in a water tank on a moving rig, which could be compared to simulated drag forces, though they did not measure lift forces and used a high level of model

scaling, potentially rendering the force values unreliable. Gibson et al. (2023) interestingly compared their CFD simulation results to early wind tunnel EFD results by Balsam and Vogel (1973) to assess the robustness of their conclusions on archaeocyathid feeding hypotheses. While not analysing the palaeobiology of an extinct organism, Davis et al. (2019) carried out a more holistic study on extant horseshoe crabs, using Particle Image Velocimetry (PIV) to track flow around the horseshoe crab model in experiments and using this to validate fluid flow simulations. Dynowski et al. (2016) carried out a similar study, examining flow patterns around an extinct crinoid species using CFD and experimental validation with PIV.

It is imperative that more work is carried out on experimental validation of palaeobiological CFD simulations, particularly for arthropods. We therefore aim to produce a protocol for ‘Experimental Fluid Dynamics’, an area of research to broadly validate the results of CFD simulations in palaeobiology. This manuscript reports ongoing work to this end.

Materials and methods

Model production

Digital models of extinct animals, trilobites initially, were created manually in software Blender, or sourced from published literature (e.g., Song et al., 2021) or online repositories (e.g., Sketchfab). These were then refined to allow for 3D-printing of models (Fig. 2A and B). Test models were printed through Protolabs Network [hubs.com] or on-site facilities at the University of Portsmouth, UK. Models were printed by stereolithography (SLA), which uses UV light to cure polymer resin, and provides a balance between cost and precision for printed prototypes (Fig. 2C and D). The 3D printing of animal models is a balance between several considerations (which may be analysed through design for manufacturability (DFM) analysis during model production): the scaling of the model, where life-size is ideal so as not to have to scale experimental measurements or change the density of the fluid, but often this is too small to enable precise printing of morphological features; the thickness of the modelled walls (thin model walls leads to instable models); surface intricate features, such as textures, which may impact experiments but are increasingly difficult to model at smaller sizes; and inclusion of intricate morphological features, such as spines, which will also impact experiments but are difficult to model accurately and without breakage (e.g., Fig. 2E).

The protocol presented here does not require the printed models to have comparable density to a real-world organism, because the model is always fixed in position (to the beam; see below). However, if planned experiments do not wish to fix the model to a similar structure, or the experiments plan to test hypotheses that involve extensive model movement (e.g., the moment of overturning in flow), then model density would be an important consideration.

Force measurements

All circuitry equipment used to measure forces exerted by the flow on the model were created by SparkFun [sparkfun.com]. Lift and drag forces were each measured by one 100g capacity compression mini straight

bar load cell (TAL221), wired to a Qwiic Scale amplifier (NAU7802), which was then connected using Qwiic cables to a Qwiic Mux Breakout board (TCA9548A) and this to an OpenLog Artemis open-source data logger. Load cells translate pressure into electrical signals, measuring the electrical resistance proportional to the strain applied to the load cell. The OpenLog Artemis was then connected via USB-C to a MacOS laptop running Arduino 1.8.18, with force data logging directly onto the Arduino Serial Logger. Force data logging can also take place directly to a microUSD card inserted in the OpenLog Artemis. The velocity profile of the flow can be measured using an ultrasonic Doppler velocity profiler (UDVP). The SparkFun circuitry set-up represents a low-cost solution to force measuring for research; all SparkFun components are inexpensive, rely on open-source programming, and are accessible thanks to extensive online community support.

Load cells used were rated only to IP65 (dust-tight and protected from water from a nozzle), rather than being immersible for brief periods (IP67) or fully submersible (IP68). This therefore necessitated rigging of the load cells above the water flow (see below). This reflects the technological limits of force measurement capability; aluminium alloy load cells can measure at the low force values being exerted on small models in low flow but are not submersible (best waterproofing available to purchase was IP66), while stainless steel is submersible but cannot measure force values low enough as it bends less easily.

Jig production

A jig to support the load cells and beam connecting to the model was modelled as a Computer-Aided Design (CAD) file (Fig. 3), then built in a workshop out of acrylic (Fig. 4A and C) and the load cells screwed onto the jig. A beam is used to attach the 3D-printed model to the jig, with the beam initially made of hollow aluminium and to be replaced with a thinner carbon fibre rod. The beam can be unscrewed and connected to a joint enabling force recording by either of the load cells. One load cell is mounted with the compression force parallel to the beam movement direction to measure drag, and the other load cell is mounted perpendicular to this to measure lift.

The jig was then mounted above an Armfield S6 linear flume tank using acrylic sheets and g-clamps on a dolly that moves on rails along the length of the flume tank (Fig. 4). The model was mounted on the end of the beam in the flume and the other end of the beam screwed into the jig, with the beam used of a length to reflect a hypothetical benthic (seafloor) or pelagic (vertical middle of the flow) lifestyle.

Experiments

With the model mounted on the beam in the flume tank at the required vertical height, attached to the jig with load cells logging force data, the water flow in the flume tank was then turned on (Fig. 4). The inflow speed was balanced with the height of the paddle at the outflow to modulate the flow speed and depth depending on desired values. The forces acting on the model will be logged onto computer or microSD card through the OpenLog Artemis.

Discussion

The preliminary protocol presented here may be used to perform experimental validation of CFD simulations. The lift and drag force values measured by the load cells record the forces exerted by the flow on the animal model, and can be used to assess palaeoecological hypotheses. The force and velocity values measured may be qualitatively compared to those produced through CFD simulations using the same digital models that are 3D-printed and analysed by EFD, to determine if the magnitudes are comparable. Alternatively, quantitative validation of the CFD simulation results could be performed by statistical analysis, testing for a significant difference between the force values obtained through CFD and EFD experiments.

However, this work is still in progress, with needed refinement of the mounting of the load cells, the beam material and diameter, and testing of the load cell measuring capabilities. Following this refinement, a series of validation force outputs will be produced for models representing body plans of major Palaeozoic arthropod groups. This protocol will also be used to validate specific CFD studies, with the same models used in CFD simulations 3D-printed, and the simulation parameters replicated as closely as possible. These CFD studies can then be used to address a range of postures, morphologies, and flow velocities, at a lower cost, more quickly, and with a wider range of visualisation choices than feasible for EFD analyses alone (Rahman, 2020).

Acknowledgements

The authors wish to gratefully acknowledge assistance from those at the University of Portsmouth. Chris Warden and Andy, Department of Physics, are thanked for providing much need help with circuitry. John Fearnley from the manufacturing lab is thanked for producing the jig CAD in consultation with the authors and building the physical jig. Gary Etienne is thanked for technical assistance with the flume tank lab. Roy Smith, Department of Earth Sciences, is thanked for support and for planning of future 3D printing.

Funding

HBD was funded under a Swiss National Science Foundation Sinergia grant (198691). SP was funded by a Herschel Smith Postdoctoral Fellowship, University of Cambridge. Equipment and travel costs were supported by a 2023 research grant from the Geological Society awarded to HBD, and a departmental grant from the University of Portsmouth awarded to the authors.

Author contributions

Conceptualisation – HBD, SP; Methodology – HBD, SP, NJM; Formal analysis – HBD, SP, NJM; Investigation – HBD, SP, NJM; Resources – HBD, SP; Writing – Original draft – HBD; Writing – review & editing – HBD, SP, NJM; Visualisation – HBD; Project administration – HBD, SP, NJM; Funding acquisition – HBD, SP, NJM.

Figures

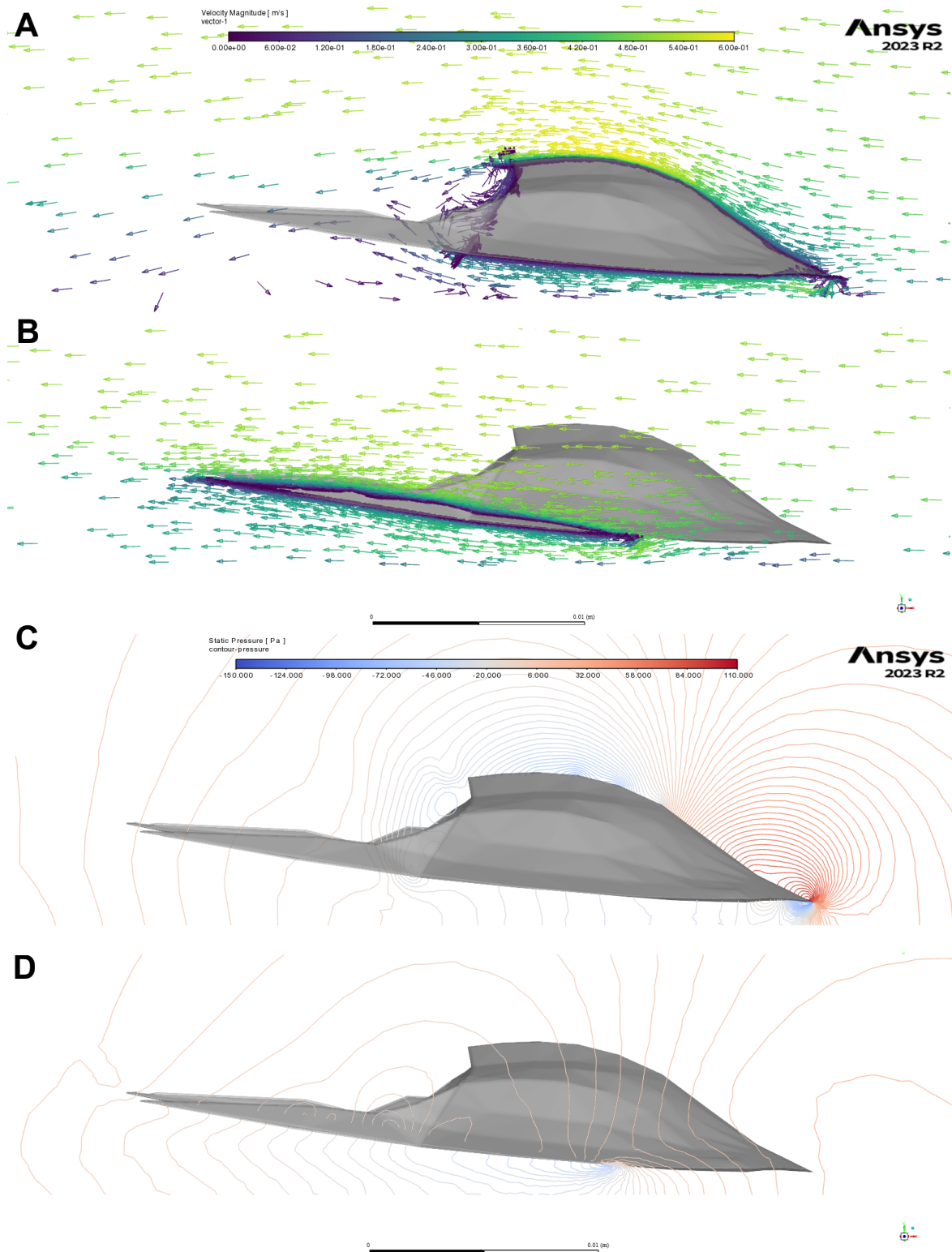

Figure 1: Example CFD simulation to test palaeoecological hypotheses; simulated flow around a hypothetical harped trilobite cephalon, to analyse the hydrodynamic importance of the genal prolongations. A, simulated velocity, projection taken through axial midline of trilobite; B, simulated velocity, projection taken through right-hand genal prolongation; C, simulated pressure, projection taken through axial midline of trilobite; D, simulated pressure, projection taken through right-hand genal prolongation. Images reproduced from Pates & Drage (2024).

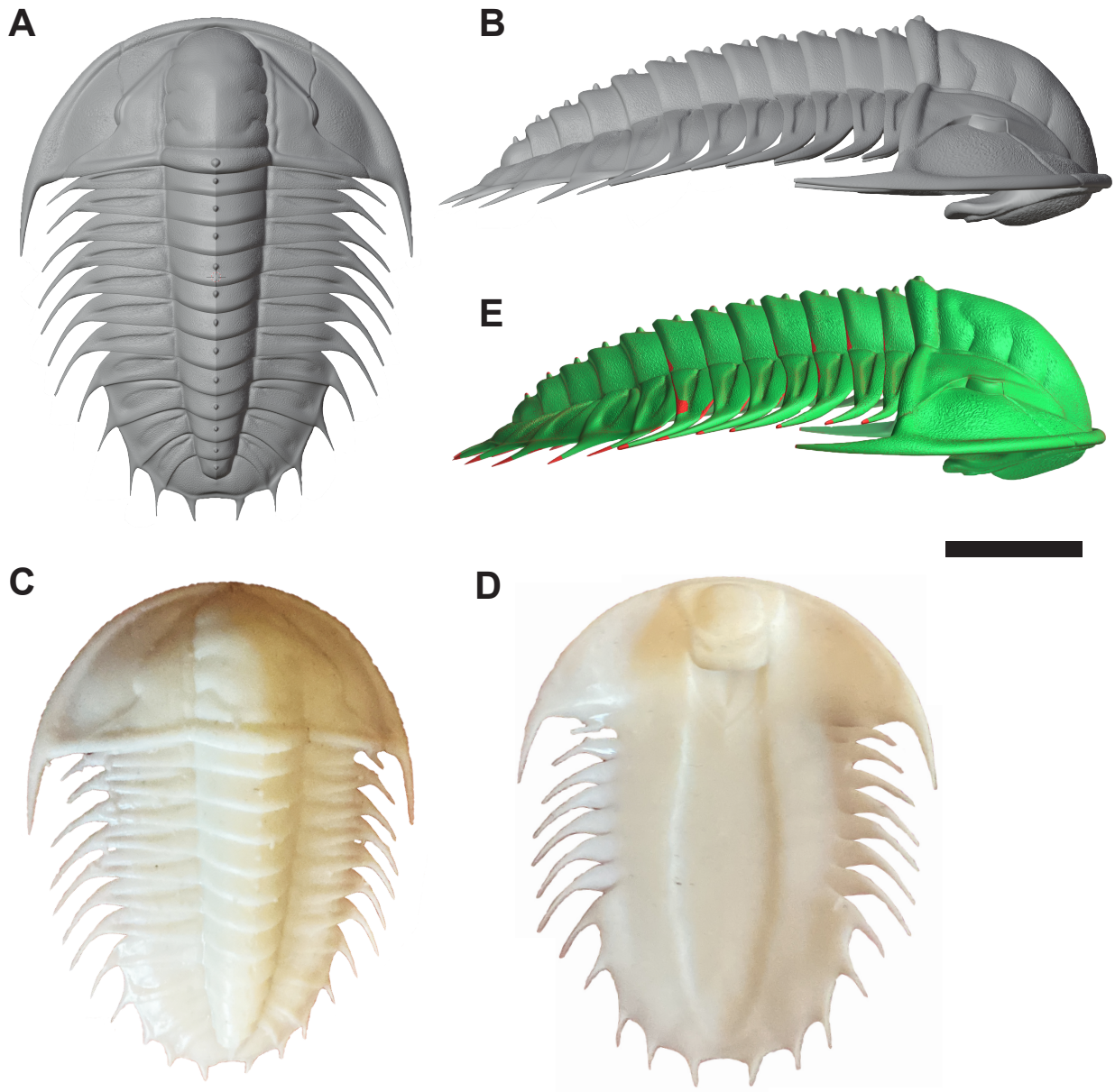

Figure 2: Example of a 3D digital trilobite model (*Olenoides serratus*) (A, B) and its physical 3D-printed counterpart (C, D). E shows, as an example of design for manufacturability (DFM) analysis, the trade-off between morphological detail and the precision of the 3D printing technique used; green parts are sufficient for printing under DFM analysis, while red parts (note the red at the tips of each spine) are unable to be properly printed. Scale bar = 1 cm. Digital model under CC-BY-NC-SA license by user Urvogel [<https://cults3d.com/en/3d-model/game/olenoides-serratus-trilobite>].

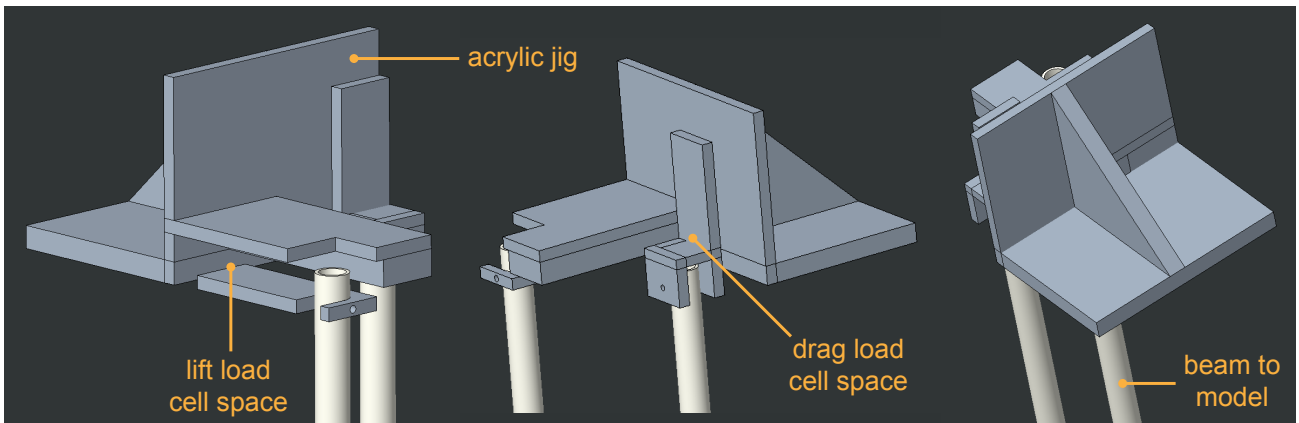

Figure 3: Various views of the Computer-Aided Design (CAD) for the jig, which was then subsequently fabricated in acrylic.

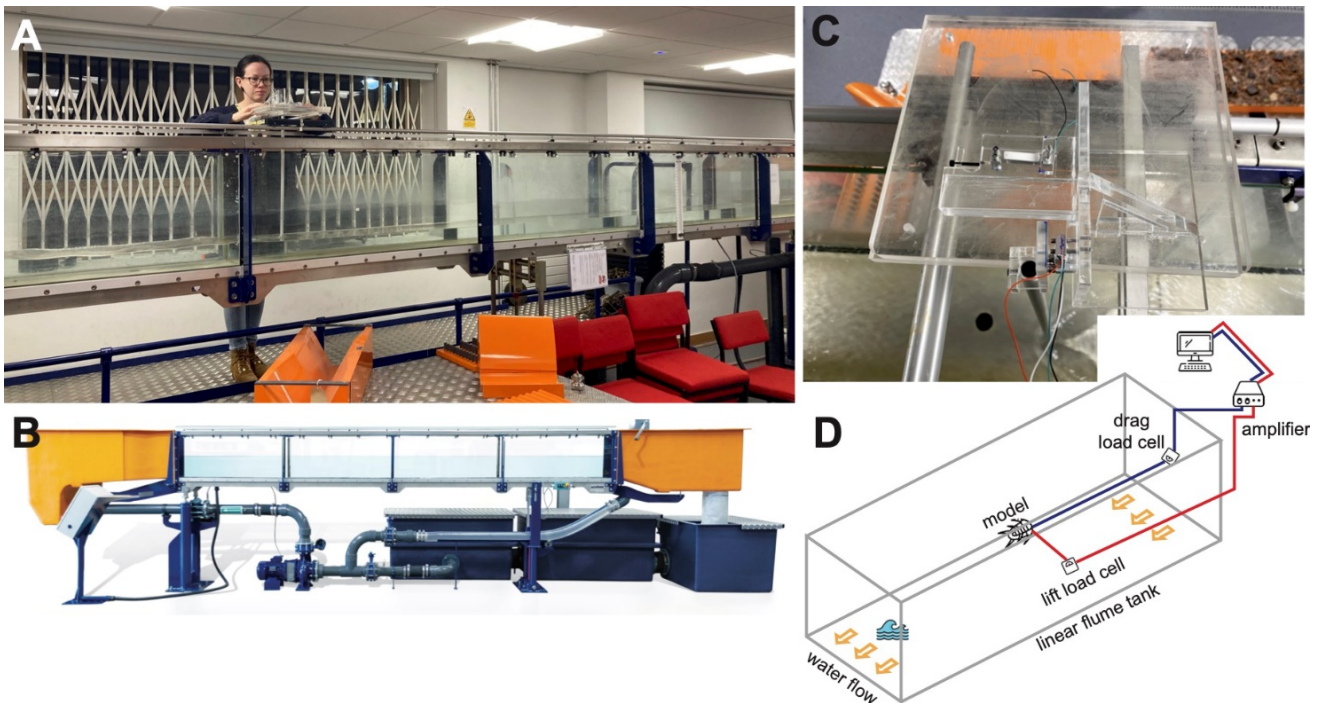

Figure 4: A, experiment in progress, with jig above flume tank and connected beam projecting into the water flow. B, Armfield S6 linear flume tank used for experimental protocol [image from <https://armfield.co.uk/product/s6-mkiii-standard-teaching-research-flume/>]. C, view of jig hosting load cells above the flume tank. D, diagrammatic representation of experimental set-up; load cells are held in the jig above the flume tank, but the diagram accurately represents their orientations to the model.

References

- Balsam, W.L. & Vogel, S. 1973. Water movement in archaeocyathids: evidence and implications of passive flow in models. *Journal of Paleontology* 47:5, 979–984.
- Bicknell, R.D.C., Schmidt, M., Rahman, I.A., Edgecombe, G.D., Gutarra, S., Daley, A.C., Melzer, R.R., Wroe, S. & Paterson, J.R. 2023. Raptorial appendages of the Cambrian apex predator *Anomalocaris canadensis* are built for soft prey and speed. *Proceedings of the Royal Society B* 290:2002. <https://doi.org/10.1098/rspb.2023.0638>.
- Davis, A.L., Hoover, A.P. & Miller, L.A. 2019. Lift and drag acting on the shell of the american horseshoe crab (*Limulus polyphemus*). *Bulletin of Mathematical Biology* 81, 3803–3822. <https://doi.org/10.1007/s11538-019-00657-2>.
- Dynowski, J.W., Nebelsick, J.H., Klein, A. & Roth-Nebelsick, A. 2016. Computational fluid dynamics analysis of the fossil crinoid *Encrinus liliiformis* (Echinodermata: Crinoidea). *PLoS ONE* 11:5, e0156408. <https://doi.org/10.1371/journal.pone.0156408>.
- Esteve, J., López, M., Ramírez, C.-G. & Gómez, I. 2021. Fluid dynamic simulation suggests hopping locomotion in the Ordovician trilobite *Placoparia*. *Journal of Theoretical Biology* 531, 110916. <https://doi.org/10.1016/j.jtbi.2021.110916>.
- Esteve, J. & López-Pachón, M. 2023. Swimming and feeding in the Ordovician trilobite *Microparia speciosa* shed light on the early history of nektonic life habits. *Palaeogeography, Palaeoclimatology, Palaeoecology* 625, 111691. <https://doi.org/10.1016/j.palaeo.2023.111691>.
- Fortey, R.A. 1985. Pelagic trilobites as an example of deducing the life habits of extinct arthropods. *Earth and Environmental Science Transactions of the Royal Society of Edinburgh: Earth Sciences* 76:2–3, 219–230. <https://doi.org/10.1017/S0263593300010452>.
- Gibson, B.M., Furbish, D.J., Rahman, I.A., Schmeckle, M.W., Laflamme, M. & Darroch, S.A.F. 2020. Ancient life and moving fluids. *Biological Reviews* 96:1, 129–152. <https://doi.org/10.1111/brv.12649>.
- Gibson, B.M., Chipman, M., Attanasio, P., Qureshi, Z., Darroch, S.A.F., Rahman, I.A. & Laflamme, M. 2023. Reconstructing the feeding ecology of Cambrian sponge reefs: the case for active suspension feeding in Archaeocyatha. *Royal Society Open Science* 10:11. <https://doi.org/10.1098/rsos.230766>.
- Gutarra, S. & Rahman, I.A. 2022. The locomotion of extinct secondarily aquatic tetrapods. *Biological Reviews* 97, 67–98. <https://doi.org/10.1111/brv.12790>.
- Hebdon, N., Ritterbush, K.A. & Choi, Y. 2020. Computational fluid dynamics modeling of fossil ammonoid shells. *Palaeontologia Electronica* 23:1, a21. <https://doi.org/10.26879/956>.

- Hou, J.-B., Hughes, N.C., Hopkins, M.J. & Shu, D. 2023. Gill function in an early arthropod and the widespread adoption of the countercurrent exchange mechanism. *Royal Society Open Science* 10:8, 230341. <https://doi.org/10.1098/rsos.230341>.
- Jacobs, D.K., Landman, N.H. & Chamberlain, J.A. 1994. Ammonite shell shape covaries with facies and hydrodynamics: iterative evolution as a response to changes in basinal environment. *Geology* 22:10, 905–908. [http://dx.doi.org/10.1130/0091-7613\(1994\)022%3C0905:ASSCWF%3E2.3.CO;2](http://dx.doi.org/10.1130/0091-7613(1994)022%3C0905:ASSCWF%3E2.3.CO;2).
- Lask, P.B. 1993. The hydrodynamic behavior of sclerites from the trilobite *Flexicalymene meeki*. *Palaios* 8:3, 219–225.
- Li, Y. & Nielsen, P.V. 2011. CFD and ventilation research. *Indoor Air* 21:6, 442–453. <https://doi.org/10.1111/j.1600-0668.2011.00723.x>.
- Li, Y.-H., Zhou, Z.-P., Zhai, D.-Y., O’Flynn, R.J.O., Tang, J., Xu, J.-W., Zhou, X.G. & Liu, Y. 2022. Hydrodynamics and sliding posture analysis of the Cambrian arthropod *Ercaicunia multinodosa*. *Palaeoworld* online access. <https://doi.org/10.1016/j.palwor.2022.09.005>.
- Liu, P., Zhang, Y., Yang, X., Wang, B., Zhang, T., Sun, J., Tang, Q., He, K., Hao, W., Yue, N., He, X. & Han, J. 2022. Hydrodynamic simulations of millimeter-scale Cambrian sedentary medusozoans. *Journal of Geophysical Research* 127:10, e2022JG006854. <https://doi.org/10.1029/2022JG006854>.
- Miller, J. 1972. Aspects of the biology and palaeoecology of trilobites. University of Manchester thesis. <https://www.proquest.com/docview/2351044031?pq-origsite=gscholar&fromopenview=true&sourcetype=Dissertations%20&%20Theses>.
- Palmer, C. 2011. Flight in slow motion: aerodynamics of the pterosaur wing. *Proceedings of the Royal Society B* 278:1713. <https://doi.org/10.1098/rspb.2010.2179>.
- Pates, S., Daley, A.C., Legg, D.A. & Rahman, I.A. 2021. Vertically migrating *Isoxys* and the early Cambrian biological pump. *Proceedings of the Royal Society B* 288, 20210464. <https://doi.org/10.1098/rspb.2021.0464>.
- Pates, S. & Drage, H.B. 2024. Hydrodynamic function of genal prolongations in trinucleimorph trilobites revealed by computational fluid dynamics. *BioRxiv preprint*.
- Pearson, K. 2017. Experimental biomechanics of trinucleid fringe pits (Trilobita). Honors Papers 184, Oberlin. <https://digitalcommons.oberlin.edu/honors/184>.
- Plotnick, R.E. & Baumiller, T.K. 1988. The pterygotid telson as a biological rudder. *Lethaia* 21:1, 13–27. <https://doi.org/10.1111/j.1502-3931.1988.tb01746.x>.

- Rahman, I.A. 2017. Computational fluid dynamics as a tool for testing functional and ecological hypotheses in fossil taxa. *Palaeontology* 60:4, 451–459. <https://doi.org/10.1111/pala.12295>.
- Rahman, I.A. 2020. Computational fluid dynamics and its applications in echinoderm palaeobiology. *Elements of Paleontology*. Cambridge University Press. <https://doi.org/10.1017/9781108893473>.
- Rahman, I.A., Zamora, S., Falkingham, P.L. & Phillips, J.C. 2015. Cambrian cinctan echinoderms shed light on feeding in the ancestral deuterostome. *Proceedings of the Royal Society B* 282, 20151964. <http://dx.doi.org/10.1098/rspb.2015.1964>.
- Rahman, I.A., O'Shea, J., Lautenschlager, S. & Zamora, S. 2020. Potential evolutionary trade-off between feeding and stability in Cambrian cinctan echinoderms. *Palaeontology* 63:5, 689–701. <https://doi.org/10.1111/pala.12495>.
- Rauen, W.B., Lin, B., Falconer, R.A. & Teixeira, E.C. 2008. CFD and experimental model studies for water disinfection tanks with low Reynolds number flows. *Chemical Engineering Journal* 137:3, 550–560. <https://doi.org/10.1016/j.cej.2007.05.011>.
- Song, H., Song, H., Rahman, I.A. & Chu, D. 2021. Computational fluid dynamics confirms drag reduction associated with trilobite queuing behaviour. *Palaeontology* 64:5, 597–608. <https://doi.org/10.1111/pala.12562>.